

1 2 3 4 5 6 7 8

A

B

C

D

E

F

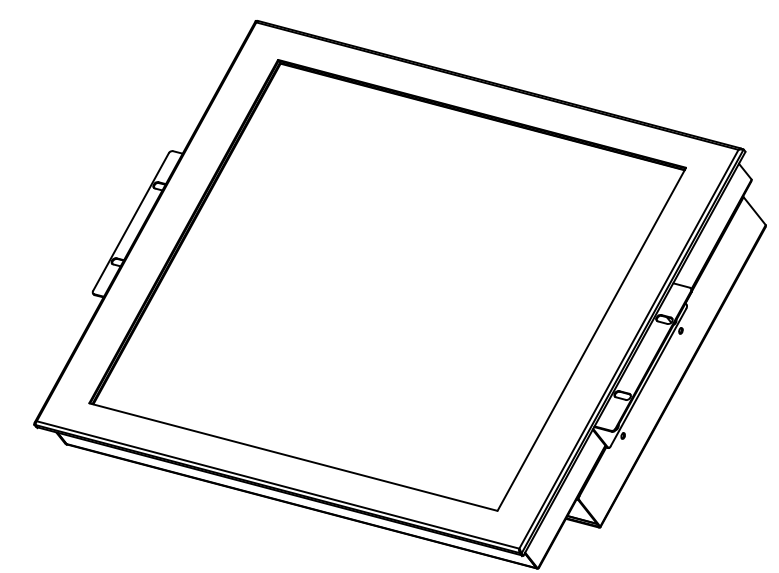
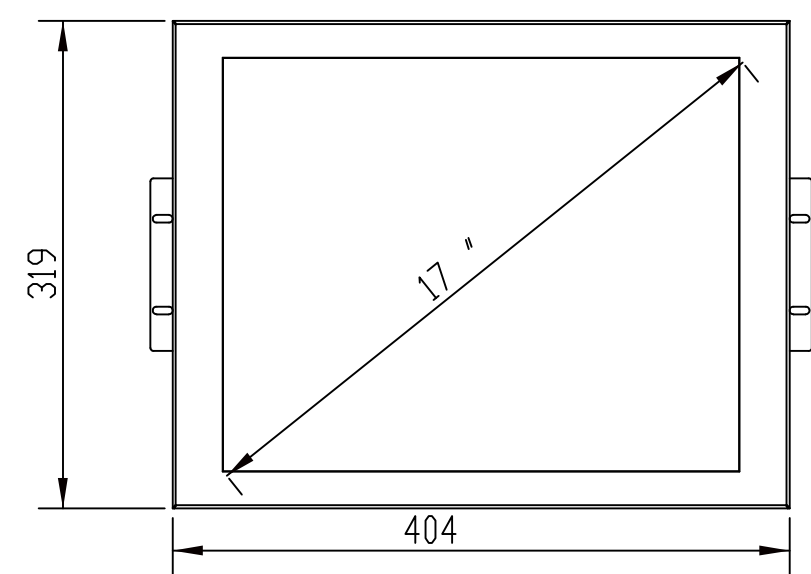
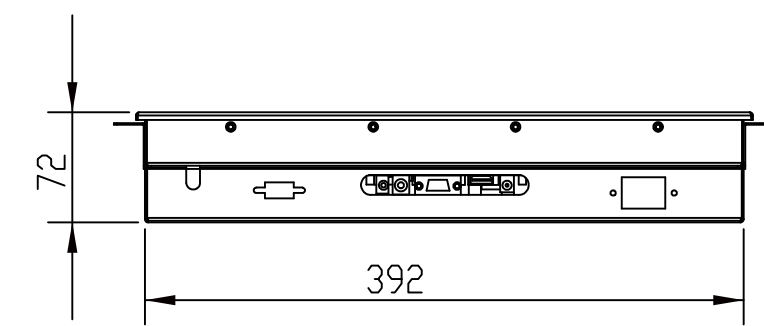
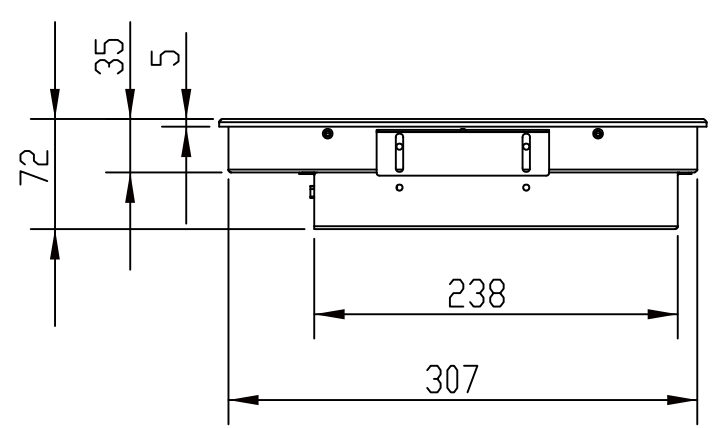
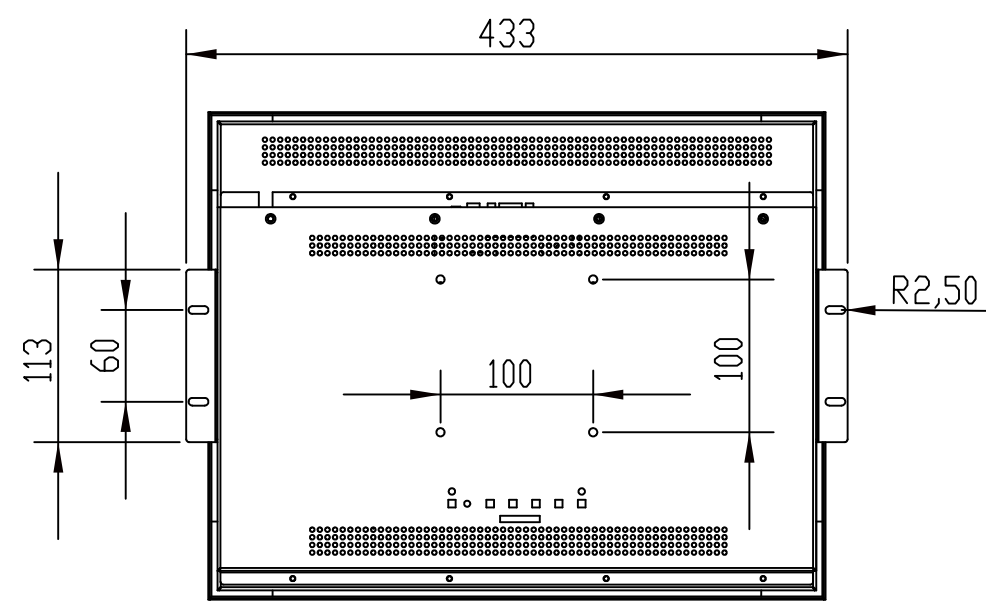

Nota:
- Découpe pour encastrement produit (394 x 309)

UNLESS OTHERWISE SPECIFIED: DIMENSIONS ARE IN MILLIMETERS SURFACE FINISH: TOLERANCES: LINEAR: ANGULAR:				FINISH: DSI - EUROTOUCH 7 rue des Artisans 31390 CARBONNE Tél: 0561978139		DEBUR AND BREAK SHARP EDGES		Ce document est la propriété de la Ste DSI-EUROTOUCH toute reproduction ou communication est interdite sans autorisation	
				DRAWN: THIBAUT		SIGNATURE:		DATE: 25/03/22	
				CHK'D:					
				APPV'D:					
				MFG:					
				QA:					
				Projet: ECRAN IS170				TITLE: ECRAN IS170 Version Montage Panneau [PM]	
Rep				Qte		N° Plan		Designation	
1						2		3	
						Matiere		Ref. Fournisseur	
						4		Fournisseur	
								DWG NO. 121 000 000	
								A3	
								SCALE: 1:5	
								SHEET 1 OF 1	